

# CB-GT380 Hardware Specifications

This document provides hardware and electrical documentation for the Controller Board Rev. B, part number CB-GT380. This is the same LCD controller board integrated with the 3.8" LCD Starter Kit (STK-GT380) and the 3.8" LCD Module Kit (MK-GT380). References to software in this document refer to the Amulet HTMLCompiler. For software documentation please see: <http://www.amulettechnologies.com/help/help.htm>.

**Figure 1. CB-GT380 Controller Board, Component Side.**

<b>PCB Size:</b>	3.65" x 2.85" (Not including tabs)
<b>LCD:</b>	Chip-on-Board, 92.2 x 71.5mm (3.8" diagonal); 320 x 240, monochrome, black on white or blue on white; Viewable area: 78.78 x 59.58mm Viewing Direction: 6 o'clock
<b>Dot Pitch:</b>	0.24 x 0.24mm
<b>Dot Size:</b>	0.22 x 0.22mm
<b>Touch Panel:</b>	4-wire resistive analog; active area is 78 x 59mm; utilizes full

	320 x 240. NOTE: Since the touch panel is touch activated, do NOT allow your mounting hardware to apply any compression forces <a href="#">inside the active area!</a>
<b>Backlight:</b>	LED, brightness adjustable via digital pot.
<b>Contrast:</b>	Adjustable via digital pots, Temp compensated
<b>Operating Temp:</b>	-20° to 70°C
<b>Storage Temp.:</b>	-30° to 80°C
<b>Power:</b>	5V +/- 10% @ 250mA
<b>SRAM:</b>	128k-Bytes
<b>Flash:</b>	512k-Bytes (448k-Bytes available)
<b>Serial Port:</b>	RS-232, 9-pin DIN, up to 115.2 Kbps

**Table 1. PCB Specs**

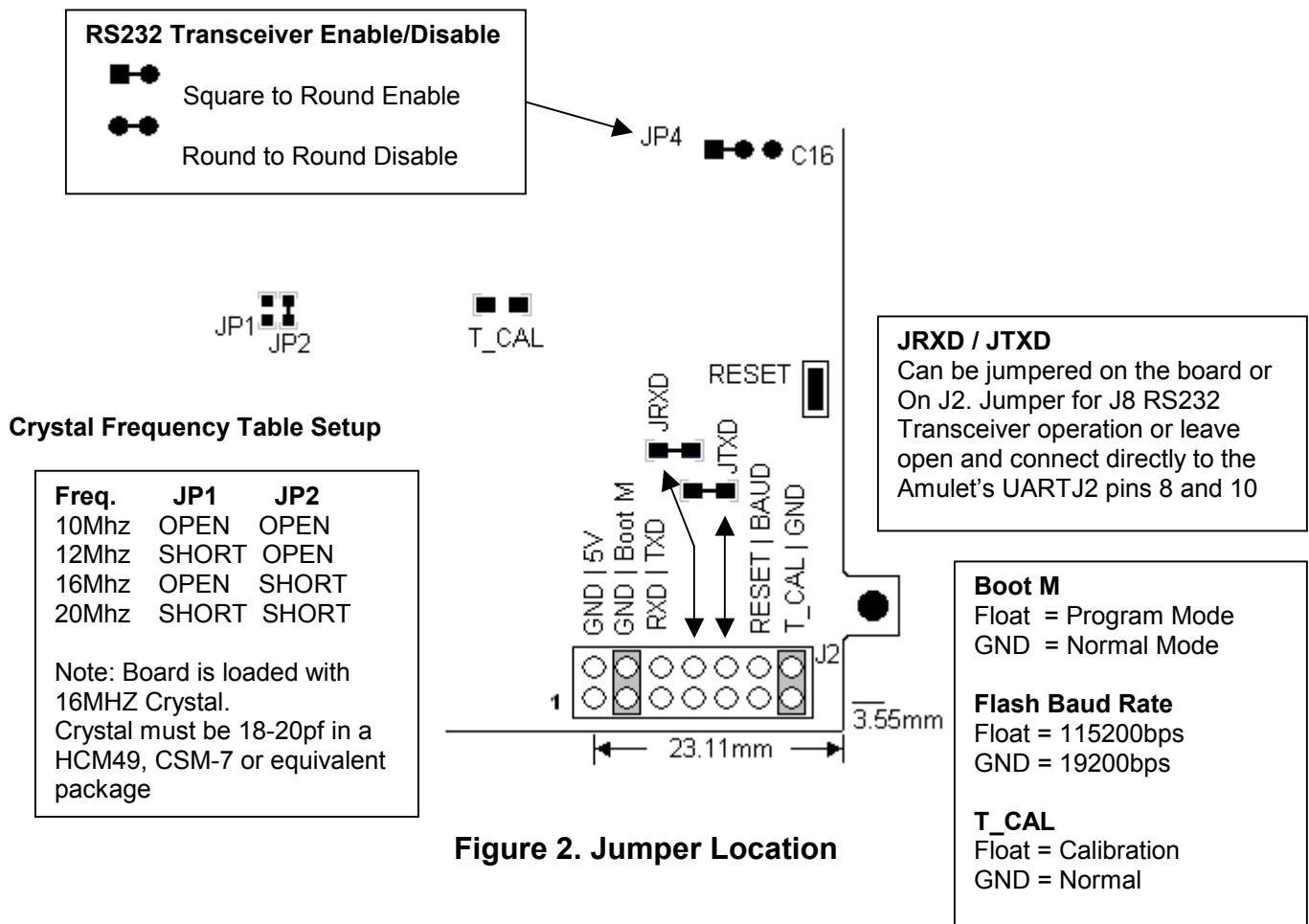

**Figure 2. Jumper Location**

## J2 Interface Header

Pin #	Signal	Description
1	GND	<b>Ground</b>
2	5V	<b>Voltage In 5V +/- 10% @ 250mA</b>
3	GND	<b>Ground</b>
4	Boot M	<b>Boot Mode</b> Float = Program Mode, GND = Normal Mode
5	RXD	<b>R1IN from RS232 Transceiver</b>
6	TXD	<b>T1OUT from RS232 Transceiver</b>
7	R1OUT	<b>RXD Input to RS232 Transceiver R1OUT (JRXD)</b>
8	UART IN	<b>RXD to Amulet UART RXD</b>
9	T1IN	<b>TXD Input to RS232 Transceiver T1IN (JTXD)</b>
10	UART OUT	<b>TXD to Amulet UART TXD</b>
11	RESET	<b>System Reset Input.</b> An external source can initiate a system reset by driving this pin low.
12	BAUD	<b>Programming Baud Rate</b> Float = 115200 bps GND = 19200 bps
13	T_CAL	<b>Touch Panel Calibration</b> Float = Normal GND = Calibrate
14	GND	<b>Ground</b>

**Table 2. J2 Interface Header**

**Boot M (Pin 4)** -- Pin is monitored during a reboot to determine the operational mode of the controller board; jumpered to ground is the normal mode and floating is the flash program mode. The only time you should have to remove the jumper (program mode) is when the project you compiled locks up the Amulet OS to the point where it won't accept the wake up message or if the Amulet OS has been corrupted and you need to [reload the OS](#).

**BAUD (Pin 12)** -- Pin determines the baud rate used during a Flash Reprogram. If the pin is grounded, the hardware baud rate is set to 19,200 bps; if the pin is left floating, the hardware baud rate is set to 115,200 baud. This setting must match the Flash rate selected in the [Amulet Compiler software](#). By default, the pin is left floating from the factory.

**T\_CAL (Pin 13)** -- Pin is monitored during a reboot to determine if the touch panel calibration routine will be run upon every reboot. If pin is grounded, then the touch panel calibration will not be run. If the pin is not grounded, the touch panel calibration will be run upon every reboot. By default, pin 13 is jumpered to pin 14 (GND).

---

## Power Supply And Reset

Power applied via the 2.5mm connector.  
Power requirement 5 +/-10% VDC @250Ma

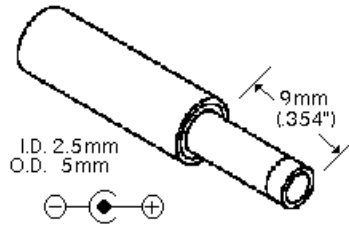

**CAUTION:** Do not reverse the polarity on the power input. Doing so will permanently damage the module and invalidate your warranty.

**Figure 3. Power Supply Input**

**Reset Switch** -- This momentary pushbutton switch resets the Amulet graphical OS chip as well as LCD power.

---

## RS-232 DB9 J8 Specs

Pin #	Description
1	N/C
2	TX (Amulet GUI module transmits data on Pin 2 while the PC receives data on Pin 2)
3	RX (Amulet GUI module receives data on Pin 3 while the PC transmits data on Pin 3)
4	Pin 4 to 6 – Jumpered
5	Ground
6	Pin 4 to 6 - Jumpered
7	Pin 7 to 8 - Jumpered
8	Pin 7 to 8 – Jumpered
9	N/C

The serial parameters for communications between the Amulet client and the server are as follows:

**Baud Rate:** 9600, 19200, 57600, or 115200bps

**Parity:** None

**Data Bits:** 8

**Stop Bits:** 1

See Communications [Protocol](#) for more information.

# Wiring the Module

## Connecting to an external micro using 3.3V CMOS UART levels

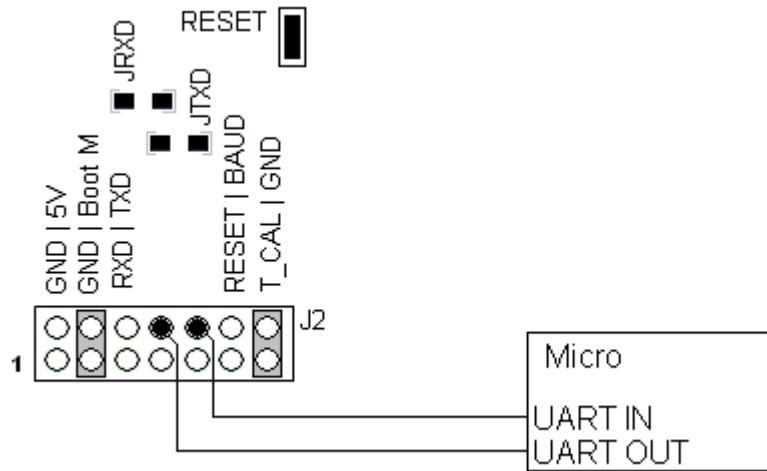

- J2 pin 1 (GND) and pin 2 (5V) to power source
- J2 pin 4 (Boot M) Grounded to pin 3 (GND) for Normal mode
- J2 pin 8 (UART IN) to Micro UART OUT
- J2 pin 9 (T1IN) Grounded
- J2 pin 10 (UART OUT) to Micro UART IN

**Note:** Make sure the JRXD and JTXD board jumpers are removed if using 3.3V CMOS levels. J2 Pin 9 (T1IN) should be grounded to remove noise from the RS-232 transceiver.

### **Notes regarding programming the Amulet serial data flash:**

If programming the serial data flash via the micro (referred to as Pass-Through Programming) there is no wiring adjustment needed. Contact [DevSupport@AmuletTechnologies.com](mailto:DevSupport@AmuletTechnologies.com) for Pass-Through Programming information.

If programming the serial data flash via RS-232 from a PC, the connection from the Micro to the Amulet UART (J2 pins 8 and 10) must be removed. To enable RS-232 levels, J2 pins 8 & 9 must be jumpered, as well as pins 10 & 11. This will enable both the DB-9 connector, as well as J2 pins 5 & 6.

## Connecting to an external micro using RS232 levels through J2 connector

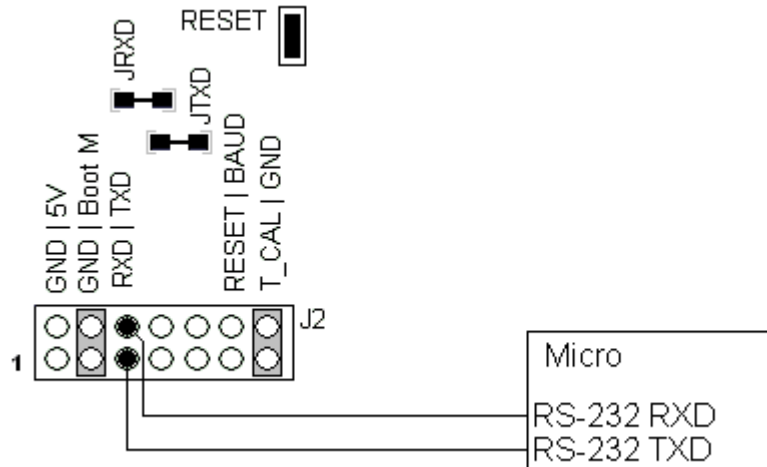

J2 pin 1 (GND) and pin 2 (5V) to power source  
J2 pin 4 (Boot M) Grounded to pin 3 (GND) for Normal mode  
J2 pin 5 (RXD) to RS232 TXD, J2 pin6 (TXD) to RS232 RXD

**Note:** Make sure JRXD and JTXD are shorted

### **Notes regarding programming the Amulet serial data flash:**

If programming the serial data flash via the micro (referred to as Pass-Through Programming) there is no wiring adjustment needed. Contact [DevSupport@AmuletTechnologies.com](mailto:DevSupport@AmuletTechnologies.com) for Pass-Through Programming information.

If programming the serial data flash via RS-232 from a PC, the connection from the Micro to the Amulet RS-232 (J2 pins 5 and 6) must be removed. This will allow programming the serial data flash from either the DB-9 connector or J2 pins 5 & 6.

---

# Module Mechanical Drawing

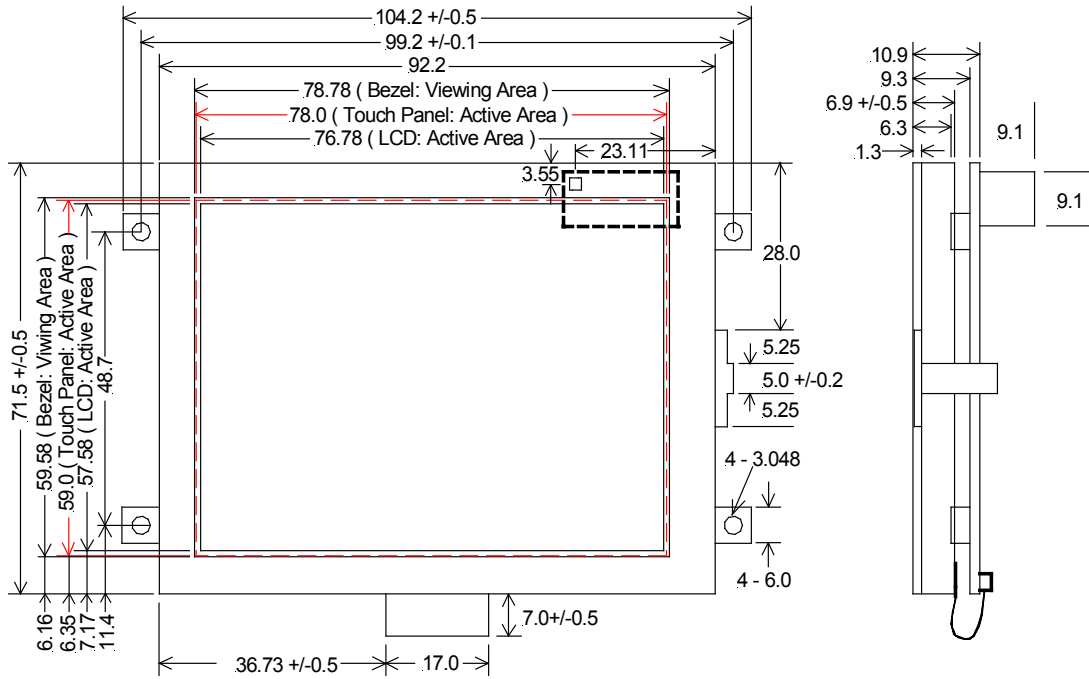

Amulet HTMLCompiler,  
 Copyright © 2002-2004 by  
 Amulet Technologies, LLC

Rev. A. 6/18/04  
 Rev. B. 8/19/04  
 Rev. C. 10/04/04