

6.003 (Fall 2009)

Quiz #1

October 7, 2009

Name:

Kerberos Username:

Please circle your section number:

<i>Section</i>	<i>Instructor</i>	<i>Time</i>
1	Marc Baldo	10 am
2	Marc Baldo	11 am
3	Elfar Adalsteinsson	1 pm
4	Elfar Adalsteinsson	2 pm

Partial credit will be given for answers that demonstrate some but not all of the important conceptual issues.

Explanations are not required and will not affect your grade.

You have **two hours**.

Please put your initials on all subsequent sheets.

Enter your answers in the boxes.

This quiz is closed book, but you may use one 8.5×11 sheet of paper (two sides).

No calculators, computers, cell phones, music players, or other aids.

1	/20
2	/20
3	/20
4	/20
5	/20
Total	/100

1. Difference equation [20 points]

Consider the system described by the following difference equation:

$$y[n] = \alpha x[n] + \beta x[n - 1] - y[n - 2].$$

a. Assume that the system starts at rest and that the input $x[n]$ is the **unit-step** signal $u[n]$.

$$x[n] = u[n] \equiv \begin{cases} 1 & n \geq 0 \\ 0 & \text{otherwise} \end{cases}$$

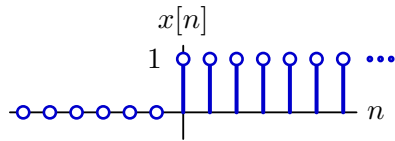

Find $y[119]$ and enter its value in the box below.

$y[119] =$

We can solve the difference equation by iterating, as shown in the following table.

n	$\alpha x[n] + \beta x[n - 1]$	$y[n]$
0	α	α
1	$\alpha + \beta$	$\alpha + \beta$
2	$\alpha + \beta$	β
3	$\alpha + \beta$	0
4	$\alpha + \beta$	α
5	$\alpha + \beta$	$\alpha + \beta$
6	$\alpha + \beta$	β
7	$\alpha + \beta$	0
...
$4i$	$\alpha + \beta$	α
$4i + 1$	$\alpha + \beta$	$\alpha + \beta$
$4i + 2$	$\alpha + \beta$	β
$4i + 3$	$\alpha + \beta$	0
...

$$y[119] = y[4 * 29 + 3] = 0.$$

Consider the same system again.

$$y[n] = \alpha x[n] + \beta x[n-1] - y[n-2]$$

b. Let $\alpha = 3$ and $\beta = 4$. Assume that the system starts at rest and that the input $x[n]$ is the **unit-sample** signal.

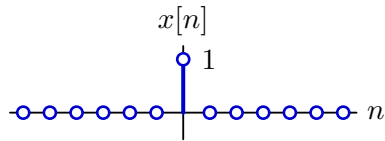

Determine coefficients A and B so that the response is

$$Aj^n + B(-j)^n ; \quad \text{for } n \geq 0.$$

Enter the coefficients in the boxes below, or enter **none** if no such coefficients can be found.

$$A = \boxed{\frac{3}{2} - j2} \quad B = \boxed{\frac{3}{2} + j2}$$

Express the difference equation as an operator expression:

$$\frac{Y}{X} = \frac{3 + 4\mathcal{R}}{1 + \mathcal{R}^2} = \frac{\frac{3}{2} - j2}{1 - j\mathcal{R}} + \frac{\frac{3}{2} + j2}{1 + j\mathcal{R}}$$

The corresponding unit-sample response is

$$\left(\frac{3}{2} - j2\right) j^n + \left(\frac{3}{2} + j2\right) (-j)^n ; \quad n \geq 0.$$

Thus $A = \frac{3}{2} - j2$ and $B = \frac{3}{2} + j2$.

2. Feedback [20 points]

Consider the following system.

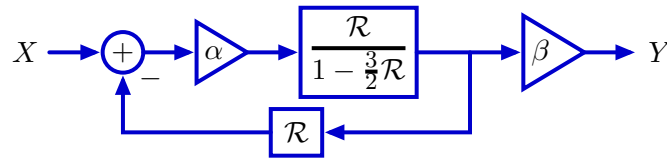

Assume that X is the unit-sample signal, $x[n] = \delta[n]$. Determine the values of α and β for which $y[n]$ is the following sequence (i.e., $y[0], y[1], y[2], \dots$):

$$0, 1, \frac{3}{2}, \frac{7}{4}, \frac{15}{8}, \frac{31}{16}, \dots$$

Enter the values of α and β in the boxes below. Enter **none** if the value cannot be determined from the information provided.

$$\alpha = \boxed{\frac{1}{2}} \quad \beta = \boxed{2}$$

Express the block diagram as a system functional:

$$\frac{Y}{X} = \frac{\frac{\alpha \mathcal{R}}{1 - \frac{3}{2} \mathcal{R}}}{1 + \frac{\alpha \mathcal{R}^2}{1 - \frac{3}{2} \mathcal{R}}} \beta = \frac{\alpha \beta \mathcal{R}}{1 - \frac{3}{2} \mathcal{R} + \alpha \mathcal{R}^2}.$$

The poles are at

$$\frac{3}{4} \pm \sqrt{\frac{9}{16} - \alpha}.$$

Now express $y[n]$ as a weighted sum of geometrics:

$$y[n] = 2 \times 1^n - 2 \times \left(\frac{1}{2}\right)^n; \quad n \geq 0$$

Thus the poles must be at $z = 1$ and $z = \frac{1}{2}$. It follows that α must be $\frac{1}{2}$. Then the system functional is

$$\frac{Y}{X} = \frac{\frac{1}{2} \beta \mathcal{R}}{1 - \frac{3}{2} \mathcal{R} + \frac{1}{2} \mathcal{R}^2} = \frac{\beta}{1 - \mathcal{R}} - \frac{\beta}{1 - \frac{1}{2} \mathcal{R}}$$

and β must be 2.

3. Scaling time [20 points]

A system containing only adders, gains, and delays was designed with system functional

$$H = \frac{Y}{X}$$

which is a ratio of two polynomials in \mathcal{R} . When this system was constructed, users were dissatisfied with its responses. Engineers then designed three new systems, each based on a different idea for how to modify H to improve the responses.

System H_1 : every delay element in H is replaced by a cascade of two delay elements.

System H_2 : every delay element in H is replaced by a gain of $\frac{1}{2}$ followed by a delay.

System H_3 : every delay element in H is replaced by a cascade of three delay elements.

For each of the following parts, evaluate the truth of the associated statement and enter **yes** if the statement is always true or **no** otherwise.

- a. If H has a pole at $z = j = \sqrt{-1}$, then H_1 has a pole at $z = e^{j5\pi/4}$.

Statement is always true (**yes** or **no**):

yes

The poles of H are the roots of the denominator of $H|_{\mathcal{R} \rightarrow \frac{1}{z}}$. But $H_1 = H|_{\mathcal{R} \rightarrow \mathcal{R}^2}$. Thus the poles of H_1 are the roots of the denominator of $H_1|_{\mathcal{R} \rightarrow \frac{1}{z}} = (H|_{\mathcal{R} \rightarrow \mathcal{R}^2})|_{\mathcal{R} \rightarrow \frac{1}{z}} = H|_{\mathcal{R} \rightarrow \frac{1}{z^2}}$. It follows that the poles of H_1 are the square roots of the poles of H .

If H has a pole at $z = j$ then H_1 must have poles at $z = \pm\sqrt{j}$. The two square roots of j are $e^{j\pi/4}$ and $e^{j5\pi/4}$. Thus $e^{j5\pi/4}$ is a pole of H_1 .

b. If H has a pole at $z = p$ then H_2 has a pole at $z = 2p$.

Statement is always true (**yes** or **no**):

no

The poles of H are the roots of the denominator of $H|_{\mathcal{R} \rightarrow \frac{1}{z}}$. But $H_2 = H|_{\mathcal{R} \rightarrow \mathcal{R}/2}$. Thus the poles of H_2 are the roots of the denominator of $H_2|_{\mathcal{R} \rightarrow \frac{1}{z}} = \left(H|_{\mathcal{R} \rightarrow \mathcal{R}/2}\right)|_{\mathcal{R} \rightarrow \frac{1}{z}} = H|_{\mathcal{R} \rightarrow \frac{1}{2z}}$. It follows that the poles of H_2 are half those of H .

If H has a pole at $z = p$ then H_2 must have poles at $z = p/2$ (not $2p$).

c. If H is stable then H_3 is also stable (where a system is said to be stable if all of its poles are inside the unit circle).

Statement is always true (**yes** or **no**):

yes

The poles of H are the roots of the denominator of $H|_{\mathcal{R} \rightarrow \frac{1}{z}}$. But $H_3 = H|_{\mathcal{R} \rightarrow \mathcal{R}^3}$. Thus the poles of H_3 are the roots of the denominator of $H_3|_{\mathcal{R} \rightarrow \frac{1}{z}} = \left(H|_{\mathcal{R} \rightarrow \mathcal{R}^3}\right)|_{\mathcal{R} \rightarrow \frac{1}{z}} = H|_{\mathcal{R} \rightarrow \frac{1}{z^3}}$. It follows that the poles of H_3 are the cube roots of the poles of H .

If H is stable, then the magnitudes of all of its poles are less than 1. It follows that the magnitudes of all of the poles of H_3 are also less than 1 since the magnitude of the cube root of a number that is less than 1 is also less than 1. Thus H_3 must also be stable.

4. Mystery Feedback [20 points]

Consider the following feedback system where F is the system functional for a system composed of just adders, gains, and delay elements.

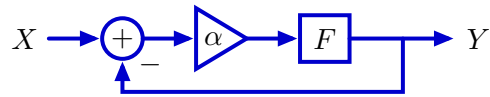

If $\alpha = 10$ then the closed-loop system functional is known to be

$$\left. \frac{Y}{X} \right|_{\alpha=10} = \frac{1 + \mathcal{R}}{2 + \mathcal{R}}$$

Determine the closed-loop system functional when $\alpha = 20$.

$$\left. \frac{Y}{X} \right|_{\alpha=20} = \boxed{\frac{2 + 2\mathcal{R}}{3 + 2\mathcal{R}}}$$

In general

$$\frac{Y}{X} = \frac{\alpha F}{1 + \alpha F}$$

If $\alpha = 10$

$$\left. \frac{Y}{X} \right|_{\alpha=10} = \frac{10F}{1 + 10F} = \frac{1 + \mathcal{R}}{2 + \mathcal{R}}$$

We can solve for F by equating the reciprocals of these expressions,

$$\frac{1}{10F} + 1 = \frac{2 + \mathcal{R}}{1 + \mathcal{R}}$$

$$\frac{1}{10F} = \frac{2 + \mathcal{R}}{1 + \mathcal{R}} - 1 = \frac{1}{1 + \mathcal{R}}$$

from which it follows that $10F = 1 + \mathcal{R}$. Then if $\alpha = 20$,

$$\left. \frac{Y}{X} \right|_{\alpha=20} = \frac{20F}{1 + 20F} = \frac{2 + 2\mathcal{R}}{1 + 2 + 2\mathcal{R}} = \frac{2 + 2\mathcal{R}}{3 + 2\mathcal{R}}$$

5. Ups and Downs [20 points]

Use a small number of delays, gains, and 2-input adders (and no other types of elements) to implement a system whose unit-sample response ($h[0], h[1], h[2], \dots$) (starting at rest) is

$$1, 2, 3, 1, 2, 3, 1, 2, 3, \dots$$

Draw a block diagram of your system below.

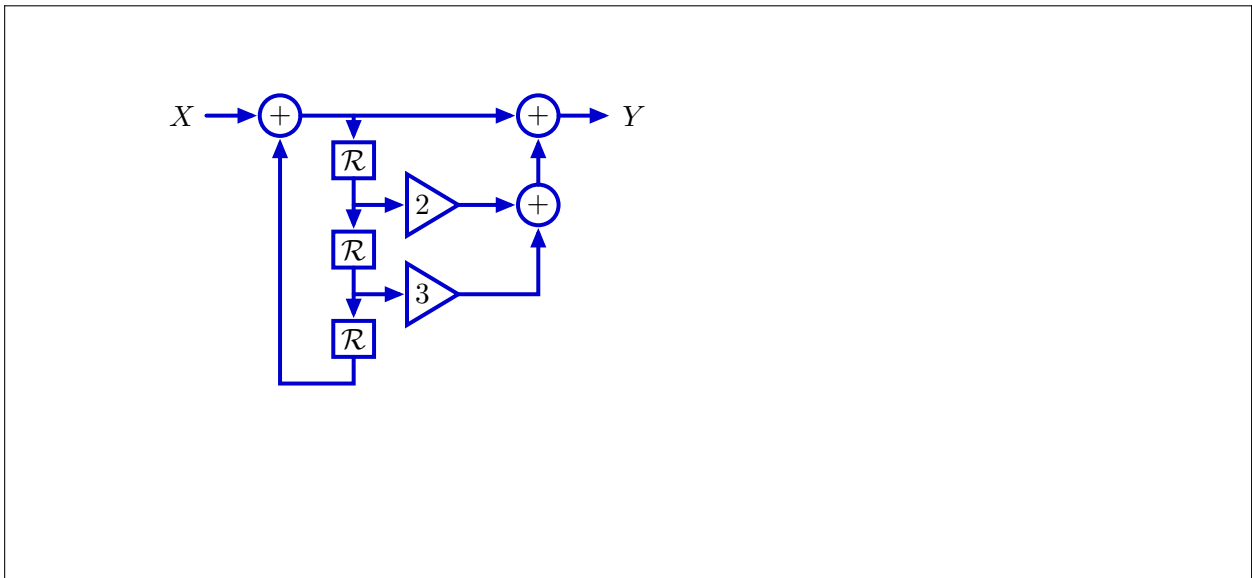

Derive the difference equation. The periodicity of 3 suggests that $y[n]$ depends on $y[n - 3]$. To get the correct numbers, just delay the input and weight the delays appropriately. The resulting difference equation is

$$y[n] = y[n - 3] + x[n] + 2x[n - 1] + 3x[n - 2].$$

A direct realization of the difference equation is shown below.

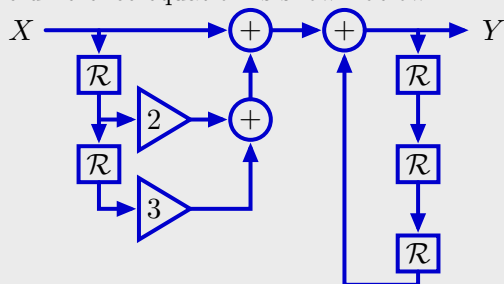

We can “reuse” 2 delays by commuting the left and right parts of this network, which gives the answer above.

